

# DISCHARGING WASTEWATER INTO MORRINSVILLE STP – WHEN MANAGED TRADE WASTE DISCHARGE REALLY DOES MATTER

*Azam Khan & Daryl Irvine*

*Pattle Delamore Partners Limited, Auckland, New Zealand*

---

## ABSTRACT

Greenlea Premier Meats Limited (GPML) own and operate an export beef processing plant in Morrinsville (Greenlea Morrinsville), and discharge wastewater as trade waste into Morrinsville Sewage Treatment Plant (Morrinsville STP), owned by Matamata Piako District Council (MPDC).

During 2009, MPDC identified that a substantial upgrade of the Morrinsville STP would be required in order to meet the requirements of a new resource consent. MPDC undertook extensive feasibility assessment to determine its preferred option. This option had cost implications in excess of \$20M for the community, including two nominated industrial trade waste discharges. MPDC stipulated that the two major industrial dischargers including GPML would contribute proportionally to the upgrade capital costs.

Greenlea Morrinsville undertook independent investigations to determine the most cost effective option for the management of the wastewater generated from its site in order to reduce its direct capital contribution for the Morrinsville STP upgrade as well its exposure to the risk of continued escalation of trade wastes charges that was signalled to the company.

Greenlea Morrinsville determined that the site needed absolute security to its business and the need to progress to develop a treatment plant that allowed the company to unhinge itself from total reliance on MPDC owned STP in future. The best practice option selected by Greenlea Morrinsville was a two-stage biological treatment system (BTS) comprising of anaerobic treatment and biological nitrogen removal (BNR) plant operated as a sequencing batch reactor (SBR). The key consents required were landuse consent to establish a wastewater treatment plant and discharge of emissions to air as a result of combustion of biogas. Strict controls on the site were imposed to maintain effectively “zero tolerance” for adverse effects related to odour, noise and visual aspects for consents that were granted through a notified process.

During 2011, a new BTS was constructed and this nestled between a rail corridor and an existing protected oak grove. The biogas generated from covered anaerobic lagoon was managed with a flare unit. A contingency biofilter was also installed to manage the odour emissions in the event of flare outages.

Following the installation and commissioning of the wastewater treatment plant, the anticipated wastewater load reductions were realised within weeks. In addition to substantial savings against the capital contribution, the BTS is providing Greenlea Morrinsville with a reduction of around 70% of annual trade waste charges.

The decision to treat wastewater on-site at Greenlea Morrinsville has significantly reduced the on-going wastewater management costs for the company while also providing more security for the site. The installation has also significantly helped MPDC in reducing its cost and need for substantial treatment at its plant.

## KEYWORDS

**Trade waste, consents, meat processing, sewage, BNR, anaerobic, biogas**

# 1 INTRODUCTION

Greenlea Premier Meats Limited (GPML) operates beef slaughter and packing plants at Hamilton and Morrinsville. The company was founded in 1993, and acquired the Morrinsville plant in 1997 which employs 150 staff.

As part of the operations at the Morrinsville plant, the meat processing activity generates up to 750 m<sup>3</sup>/d of wastewater that is discharged as a trade waste into the Morrinsville Township sewerage system and is further treated in the Matamata Piako District Council (MPDC) owned Morrinsville Sewage Treatment Plant (Morrinsville STP). Greenlea Morrinsville is one of the two major trade wastes dischargers in Morrinsville.

Greenlea Morrinsville was facing an increase in trade waste charges as a direct result of the proposed wastewater treatment system and sludge dewatering plant upgrade by MPDC for the Morrinsville STP. As the Greenlea Morrinsville plant is a large industrial waste discharger, it was required to contribute significantly to the MPDC Morrinsville STP upgrade. The proposed upgrade by MPDC at Morrinsville included establishment of a new sludge dewatering facility, with significant upgrade of the existing wastewater treatment plant. The upgrades planned by MPDC have been estimated to capital cost around \$18M. Based on the costs provided by MPDC, GPML had estimated that its share of the capital costs and operational costs as trade waste charges would be unsustainable unless GPML planned for significant reduction of the wastewater contaminants generated from the site through on-site pre-treatment.

In order to reduce these costs to an acceptable level and to remain a sustainable business in Morrinsville, GPML proposed to undertake extensive pre-treatment of the wastewater generated from its plant by establishing a biological wastewater treatment plant comprising of a covered anaerobic lagoon and an activated sludge treatment plant operated as a sequencing batch reactor (SBR). The on-site wastewater treatment plant was established in the vicinity of its processing plant. The system treated wastewater prior to its discharge into the MPDC system as a trade waste.

## 2 TRADE WASTE NEGOTIATIONS

The trade waste negotiation was undertaken over a protracted period of time as MPDC was trying to resolve the resource consents for the Morrinsville STP discharge as well as progress the trade waste agreement issues with the two major trade waste dischargers in Morrinsville. Once the resource consent for MPDC was granted, the final outcomes for the requirements for Morrinsville STP was determined and Greenlea Morrinsville was able to recognise the level of financial commitment that it had to consider to allow them to continually discharge trade waste.

### 2.1 MPDC APPROACH TO MORRINSVILLE STP UPGRADE

In late 2007, MPDC started investigations for the Morrinsville STP solids management upgrade. The issues identified were the management of historically accumulated biosolids in the final lagoon of the Morrinsville STP, and the handling, dewatering of active sludge production. The final lagoon at Morrinsville STP contains approximately 50,000 cubic metres of sludge that was required to be managed to allow the isolation of this lagoon from the treatment system. MPDC proposed at that time that the historical sludge would be left in the lagoon as a biosolids monofill. To manage continued sludge production, a new sludge dewatering facility would be commissioned at Morrinsville STP. The costs for the new sludge dewatering facility was estimated at around \$8M (June 2009) based on actual loads entering into the Morrinsville STP in 2009.

Following the costings for the sludge dewatering plant, MPDC was advised that further work would be required to determine the wastewater loadings into the Morrinsville STP. Subsequently, in July 2009, the advice received by MPDC suggested that a comprehensive upgrade of the Morrinsville STP was required to meet the likely tightening discharge limits. A series of options were developed where the capital cost ranged between \$8M - \$28M. The option recommended to MPDC was costed at an estimated \$23M. The upgrade would have resulted in the conversion of the existing sequencing batch reactor (SBR) biological nitrogen removal (BNR) plant to continuous flow reactor (CFR), addition of new clarifiers, new pre-filtration units and ultra-violet (UV) disinfection system. A new sludge dewatering plant was also proposed.

MPDC progressed the resource consents programme on the basis that the recommended option would be constructed. A new 15 year resource consent was granted to MPDC in 2009 to allow the continued discharge of treated wastewater into the Piako River.

Once the resource consent was granted, MPDC re-evaluated its position in terms of the upgrade path and a new preferred option was developed. This option consisted of maintaining the existing SBR, addition of a new SBR, addition of pre-filtration units and UV disinfection system. A new sludge dewatering plant was also proposed. This change in the preferred option provided a cost reduction to estimated \$18M.

Following the determination of the preferred option, MPDC started to develop the cost-sharing models and agreement was reached between MPDC and the two industrial dischargers that the cost sharing would be based on the marginal difference approach. This resulted in cost sharing principle where MPDC contributed to the cost of the upgrade as if no discharges from the trade wastes would occur and then added the additional costs for managing the trade waste discharge. This resulted in a cost sharing ratio of around 2:1 (MPDC:industry). The industry cost split was further distributed based on the proportional flow/loads discharged by each discharger, based on an agreed methodology.

## **2.2 CONSEQUENTIAL IMPACT ON GPML**

In the first instance, when the upgrade programme was identified as being limited to solids dewatering system upgrade, GPML started investigating methods of reducing the organic load and solids load that would have resulted in minimising the amount of biosolids being generated at Morrinsville STP as a result of the discharge from their plant.

Following the identification of further constraints that MPDC faced with the discharge of treated wastewater, GPML recognised that the cost implications it faced were no longer sustainable, based on the options that were becoming necessary for MPDC, unless substantial treatment of the wastewater generated from its plant was undertaken prior to discharge to Morrinsville STP.

In order to allow benefits realised for both parties, Greenlea Morrinsville determined that on-site treatment system with a high degree of treatment would be most preferred pathway.

## **3 DEVELOPMENT OF ON-SITE SOLUTION**

### **3.1 ENGINEERING OPTIONS ANALYSIS**

From the very early stages of options selection process, Greenlea Morrinsville made a decision that it required the best return on its investment if the company progressed to establish an on-site wastewater treatment plant. The key criterion was to develop a solution that would provide the least exposure to capital cost regret and manageable operating costs throughout the life of the new plant.

A series of options were developed for Greenlea Morrinsville that allowed the company to determine the cost/benefit of the various on-site treatment systems together with its exposure to MPDC costs for the capital costs contribution to Morrinsville STP and the corresponding trade waste charges. The alternatives considered were to:

- i. Do nothing and discharge untreated wastewater to MPDC system;
- ii. Use advanced primary screening system for solids reduction;
- iii. Install physico-chemical dissolved air flotation plant;
- iv. Construct anaerobic treatment facility; and
- v. Establish a combined anaerobic/aerobic treatment system including biological nitrogen removal (BNR).

The assessment considered the advantages and disadvantages of each option, including costs, trade waste charges, impact on future sludge costs, and having the least environmental effects. GPML determined that for long-term security, the combined anaerobic and aerobic treatment system would be the most suitable solution, prior to discharge as a trade waste into Morrinsville STP.

The selection of the anaerobic/aerobic treatment facility provided for the least environmental effects, as the system would enable future use of the treated wastewater for reuse as a non-potable water supply for stockyard wash and/or as a resource for land disposal, produces less sludge requiring off-site landfilling, reduced overall aeration energy needs for the treatment of wastewater at Morrinsville STP. The anaerobic treatment facility allowed harvesting of biogas, reducing greenhouse gas emission.

The proposed site was selected due to its physical separation from neighbouring residences and because it provided efficient utilisation of existing land (in that the area was unlikely to be redeveloped in future for any other purpose).

GPML also considered the option of discharging treated wastewater from the system to land in the future, if suitable land was identified and available for this purpose and relevant resource consent were granted.

## **3.2 RESOURCE CONSENTS PROCESS**

In order to establish an anaerobic/aerobic biological wastewater treatment system (BTS) on the outskirts of Morrinsville Township and on rural zoned land, Greenlea Morrinsville had to apply for a new landuse consent from MPDC and an air discharge permit from Waikato Regional Council (WRC). Both councils deemed the application required limited notification to the directly affected parties.

The key issues for the resource consents process were the establishment of a wastewater treatment facility in close proximity to residential dwellings, the likelihood of odour generation, the perceived negative visual impacts, and the management of biogas generated from the anaerobic treatment facility. Other operational matters that needed to be considered included construction noise and hours of work, works involving removal of trees from scheduled oak grove woodlot, erosion management, traffic movements, noise and dust. Other aspects related to management of groundwater and stormwater.

Greenlea Morrinsville developed a comprehensive assessment of environmental effects for the proposal and undertook consultation with the affected parties to assure that the neighbours that the effects at their residences would be no more than minor.

One of the key aspects during the resource consents was addressing the biogas discharges from the anaerobic treatment system to manage the discharge of any objectionable odour. Greenlea Morrinsville had proposed the thermal destruction of all captured biogas exiting the covered anaerobic lagoon using a flare unit. Greenlea Morrinsville also proposed that in the event the flare unit was not operating, a contingency biofilter was also provided to manage odour.

WRC undertook an external technical review of the proposal that was related to the management of biogas and odour from the anaerobic treatment facility. The external technical review concurred with Greenlea Morrinsville's assessment of the issues and the likelihood of the level of adverse effects.

The resource consents were progressed to a consent hearing where Greenlea Morrinsville demonstrated that proposal met all the concerns of the neighbours and effects on the receiving environment were no more than minor. MPDC supported the proposal as the establishment of the BTS reduced the risk to Morrinsville STP and the operational costs associated with running the Morrinsville STP. The consents were granted by both MPDC and WRC with strict conditions in relation to various aspects of the proposal.

## **3.3 WASTEWATER TREATMENT SYSTEM**

### **3.3.1 WASTEWATER FLOW AND QUALITY**

The meat processing plant produces a high strength wastewater with high biochemical oxygen demand (BOD), chemical oxygen demand (COD), total Kjeldahl nitrogen (TKN) and oil & grease. The design flow rate selected was 1,000 m<sup>3</sup>/d. The influent characteristics for the process design of the treatment plant are given in Table 1.

Table 1: Influent Characteristics utilised for Design

Parameter	Concentration
Total Suspended Solids (TSS)	2,500
Biochemical Oxygen Demand (BOD)	3,000
Chemical Oxygen Demand (COD)	6,500
Total Kjeldahl Nitrogen (TKN)	350
Total Phosphorus (TP)	35
pH	6.5 – 7.5
Notes:	
1. All units in mg/L except for pH (pH units)	
2. The design concentrations based on maximum concentrations for the 3 years of monthly monitoring data.	

### 3.3.2 BIOLOGICAL TREATMENT SYSTEM

Prior to the new BTS, Greenlea Morrinsville already had in place a primary sump where the raw wastewater was collected and then discharged into the MPDC sewerage system. This primary sump was included as part of the new treatment system. From the primary sump, the raw wastewater was pumped over two stream crossings into the new BTS.

The BTS comprises of a 5,000 m<sup>3</sup>, covered anaerobic lagoon. The anaerobic lagoon was lined with HDPE and also a bank-to-bank HDPE cover was anchored to prevent the escape of all biogas generated. A stormwater collection system was installed to manage the rainwater collected on top of the cover. Provision is made on the cover to allow periodic controlled desludging of the anaerobic lagoon to occur.

The anaerobically treated wastewater is then discharged via gravity on a controlled fill cycle into a 4,500 m<sup>3</sup> BNR plant operated as an SBR. Figure 1 shows the general process layout of the on-site wastewater treatment system. Photo 1 shows the covered anaerobic lagoon with stormwater collection system and biogas flare unit in the background.

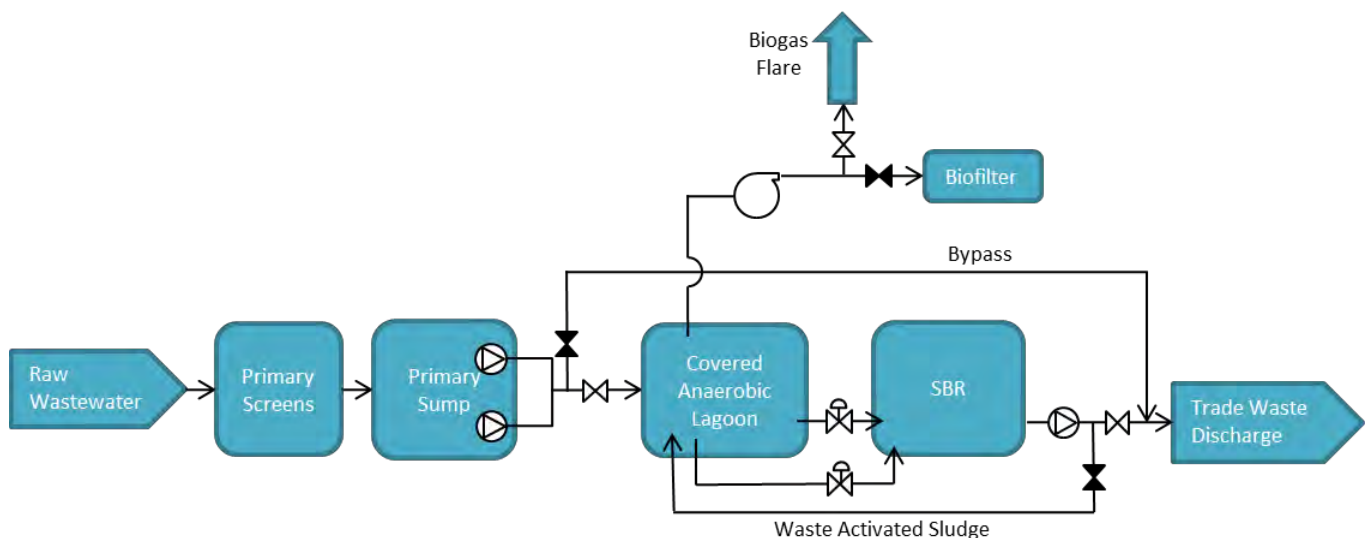

Figure 1: General Process Layout of the BTS



*Photograph 1: Part of Covered Anaerobic Plant with Biogas Flare in Operation*

The SBR was designed with a combined FILL/AERATE cycle of 6 hours, with FILL stopping once a set volume was transferred from the covered anaerobic lagoon. The aeration is controlled either by dissolved oxygen (DO) management or pH management. Following the aeration, a SETTLE phase of 1 hour is provided, with a DECANT cycle of around 5 hours. The aeration requirement is based on managing the BNR process, with 66 kW of mechanical aeration capacity installed (additional provision of 22 kW provided for future). The SBR operates on a two 12-hour cycle per day regime with volume controls as being the primary controller and level controls as the secondary control. When the aeration demand is reduced, then a dedicated mixer starts automatically to ensure that the SBR mixed liquor remains in suspension.

When the process flows through the treatment plant are reduced, a luxury anoxic phase is started with the FILL commencing prior to the AERATE phase. This promotes both separate denitrification as well as simultaneous nitrification/denitrification in a given cycle.

The wasting of the biosolids is undertaken in an intermittent batch basis with the waste activated sludge (WAS) discharged to the covered anaerobic lagoon.

Photo 2 shows the SBR in AERATE phase with the control room and the biogas flare unit in the background.



*Photograph 2: SBR Plant in Aeration Phase*

### **3.3.3 BIOGAS MANAGEMENT**

Biogas is a by-product of anaerobic digestion of wastewaters containing organic matter. Biogas consists predominantly of methane (50-75%) and carbon dioxide (25-50%) but also contains trace gases such as hydrogen sulphide (3,000 ppm), hydrogen and nitrogen. Other than hydrogen sulphide, small amounts of other odour generating compounds are also present.

All biogas is collected and then discharged to a flare unit for combustion. The covered anaerobic lagoon is operated with a negative pressure (under vacuum) with the flare unit being operated on pressure control. During peak production up to 190 Nm<sup>3</sup>/hr of biogas, with methane concentration of 75%, is combusted.

A small bark bed contingency biofilter with 9 m<sup>3</sup> bed volume was also constructed to provide for biogas biofiltration in the event the flare or the extraction blower is malfunctioning. The empty bed residence time (EBRT) for the biofilter is in excess of 4 minutes (at diverted flow requirement) well above 1 minute EBRT requirement for odour control in biofilters. While the biofilter may reduce a limited amount of the methane in the biogas, it reduces the odorous hydrogen sulphide levels in the biogas so that odours are not noticeable at the nearest residential receptor, even during flare malfunction. The biogas from the level control sump at the anaerobic lagoon and an emergency vent on top of the anaerobic lagoon cover is piped to the biofilter at all times. This small amount of continuous supply of gases enables the biofilter to maintain and support the population of bacteria that will reduce odour.

The use of the biofilter as a contingency biogas management system has proved to a robust method of biogas treatment when the gases from the covered anaerobic lagoon was generated with low methane content during anaerobic treatment process commissioning.

### **3.4 COMMISSIONING**

Commissioning challenges were limited to biogas flare unit flame-outs in the early stages of the plant operation. This was resolved with some changes to the mechanical/control equipment associated with the biogas controller and the flare stack.

During the start-up of the BTS, the biogas generation was poor and all emissions from the covered anaerobic lagoon were passed through the biofilter. Some localised odour was present at the biofilter until the microbial population within the biofilter was established.

The anaerobic lagoon microbial biomass took a while to develop the required methanogenic bacterial population and as such there was an increased load into the SBR to above the design loads expected for the SBR. For a period of time, sludge bulking within the SBR occurred and settling problems had resulted during the settle phase of the SBR. Within 8 - 12 weeks of commissioning of the anaerobic lagoon, the loads into the SBR had reduced to the point that a carbon shortage was being realised for optimum nitrogen removal. The peak performance of the BTS system was realised after 3 months of process commissioning. The plant was commissioned on 1 September 2011.

### **3.5 TREATMENT PLANT PERFORMANCE**

Monitoring data from December 2011 to July 2012 was used to evaluate the performance of the Greenlea Morrinsville BTS process. The summary of the monitoring data for the discharge from the BTS is given in Table 2.

The results show that BOD concentrations have generally been very low and significant nitrification has occurred in the SBR as the anaerobic treatment system treatment efficiencies has increased over time. The TSS concentration in the decant (final discharge) progressively reduced as the settleability of the mixed liquor improved.

Table 2: Trade Wastes Discharge Characteristics

Parameter	Average	Range
Total Suspended Solids	121	39 - 197
Biochemical Oxygen Demand	23	5 – 54
Soluble Chemical Oxygen Demand	121	72 - 220
Total Kjeldahl Nitrogen	43	29 - 56
Ammoniacal Nitrogen	34	18 - 56
Total Phosphorus	28	23 - 33
Total Oxidized Nitrogen	103	82 - 135
pH [pH units]	6.7	5.7 – 7.7
<i>Notes:</i> 1. All units in mg/L except for pH (pH units) 2. The sampling period between 1 December 2011 – 15 July 2012 based on monthly sampling for compliance purposes.		

As nitrification levels increased, a drop in the SBR pH was observed. To better manage the amount of nitrification/denitrification, the SBR operation was changed from DO control to pH control. This resulted in more efficient use of aeration within the SBR. The demand for additional organic carbon to promote denitrification has been supplied from an alternative discharge line from the anaerobic lagoon, however, the anaerobic lagoon has progressively become very efficient at organic carbon reduction, reducing the supply of available carbon to allow complete nitrogen removal. In the event the carbon shortage continues and limits denitrification, then a modification to the influent line into the covered anaerobic lagoon to allow diversion of a highly metabolizable carbon effluent into the SBR will be undertaken.

The SBR has been operated for an extended period of time without the need for sludge wasting, resulting in increased use of endogenous decay of the mixed liquor within the SBR.

One of the key aspects of the BTS has been the minimal amount of operator input into the running of the treatment plant once the commission was completed. Greenlea Morrinsville have SCADA links to the treatment plant operation, however, operational changes are kept to a minimum allowing the plant to operate without attendance. The operator attendance is less than 1 hour per day to check the mechanical equipment, calibrate instruments (when required) and stormwater management for the cover.

### 3.6 REDUCTION OF TRADE WASTES

The key compliance limits for trade waste discharge is based on flow, TSS, BOD and TKN. The flow from Greenlea Morrinsville averages at around 650 m<sup>3</sup>/d. Table 1 shows the key contaminant concentrations in the trade waste prior to the upgrade and after the upgrade.

Table 3: Comparison of Average Trade Wastes Reduction			
Parameter	Pre-Upgrade	Post-Upgrade	Reduction
Total Suspended Solids	1,335	121	91%
Biochemical Oxygen Demand	1,800	23	99%
Total Kjeldahl Nitrogen	255	43	83%
<i>Notes:</i> 1. All units in mg/L 2. The sampling period between 1 December 2011 – 15 July 2012 based on monthly sampling for compliance purposes.			



The discharge from the BTS generally has well nitrified effluent with average oxidised nitrogen concentrations of 100 mg/L. Because there is a large organic load from the other large industrial discharger, the disposal of nitrified effluent into the MPDC system generally would not create a negative impact on Morrinsville STP. However, Greenlea Morrinsville and MPDC have a very close working relationship, such that process modification at the Greenlea BTS can be changed to allow further reduction of oxidised nitrogen if required.

Greenlea Morrinsville has realised significant savings in its trade waste charges with the implementation of the BTS. Apart from the direct savings in the capital costs contribution, which has been in excess of the costs for the establishment of the BTS, the annual trade waste charges for further management of the discharged treated wastewater by MPDC is around 15% of the costs if Greenlea Morrinsville did not undertake any on-site pre-treatment.

## **4 CONCLUSIONS**

Faced with the prospect of substantial and unsustainable increases in its trade waste charges, Greenlea Morrinsville established an onsite biological wastewater treatment system comprising of a covered anaerobic lagoon and BNR plant operated as an SBR for the treatment of meat processing wastewater. The treated wastewater is then discharged into the MPDC owned sewer system to be further treated at Morrinsville STP.

There have been no adverse effects arising from operating the wastewater treatment plant in close proximity of residential dwellings despite odour emissions being the key concern raised during the resource consents process. The combustion of the biogas generated from the anaerobic lagoon is well managed and the infrequent diversion to contingency biofilter has resulted in no objectionable odour emissions.

The implementation of the on-site wastewater treatment system has allowed Greenlea Morrinsville to reduce its trade wastes loads in excess 90% for TSS and BOD load and above 80% for TKN. The operation of the treatment plant is managed in such a way that the biosolids generation is kept to a minimum.

Significant capital costs contribution and trade waste charges were realised by Greenlea Morrinsville with the implementation of its own wastewater treatment system.

The establishment of the Greenlea Morrinsville BTS has also assisted MPDC in treating reduced wastewater loads and the consequential management of wastewater biosolids.

## **ACKNOWLEDGEMENTS**

The authors take this opportunity to thank Greenlea Premier Meats Limited for their assistance on this project and allowing the use of monitoring data for this paper.